

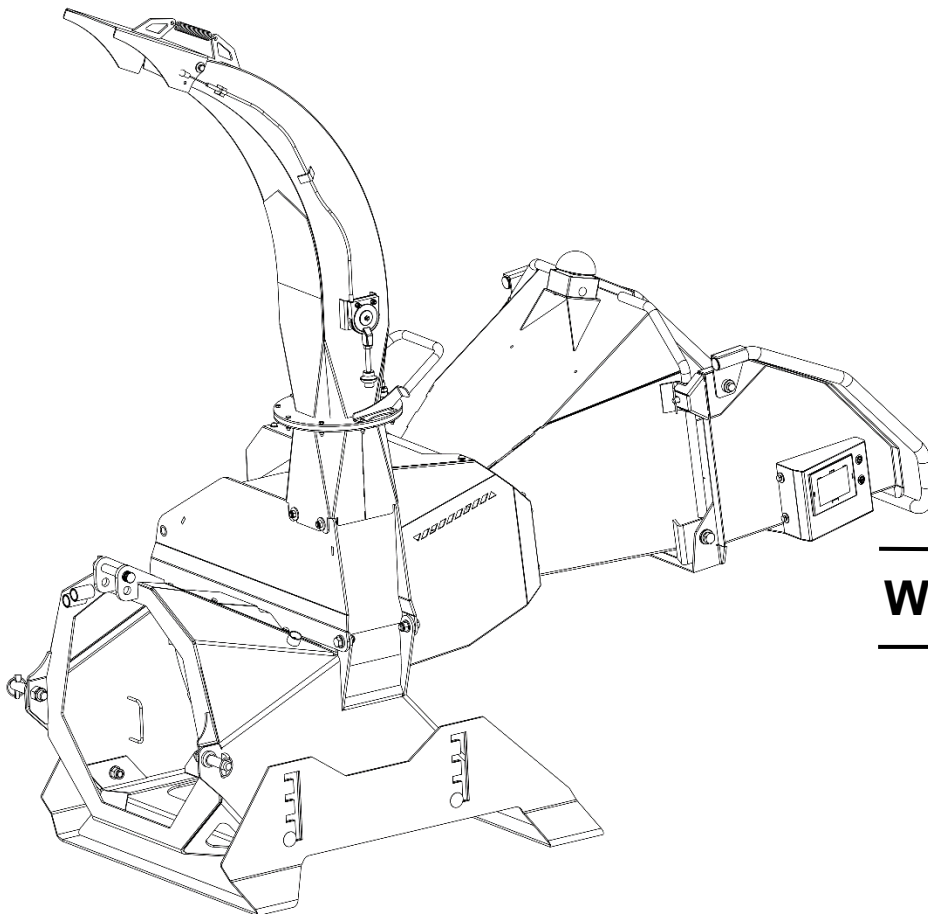

WOOD CHIPPER OPERATOR'S MANUAL



WCEP150



Please carefully read this manual and follow all the instructions. Failure to comply with the warnings and precautions may result in serious injury or death.

Table of Content

SAFETY PRECAUTIONS	3
<i>Safety Always Comes First</i>	3
<i>General Safety</i>	3
EQUIPMENT SAFETY GUIDELINES	4
<i>Operator safety</i>	5
<i>Maintenance Safety</i>	5
HYDRAULIC SAFETY	6
SAFETY TRAINING	7
PREPARATION	7
TRANSPORT SAFETY	8
<i>Storage Safety</i>	8
<i>Safety Signs and Model Decals</i>	9
<i>Safety signs</i>	9
<i>Safety decals</i>	10
PRODUCT SPECIFICATION	11
<i>Implement Specification</i>	11
<i>Implement Identification</i>	12
UNPACKING	13
PRODUCT OVERVIEW	14
ASSEMBLY & SET-UP	15
<i>Hitch Assembly</i>	15
<i>Tractor Hook-up</i>	16
<i>Driveline Installation</i>	18
<i>Driveline length check</i>	19

<i>Customize driveline</i>	19
<i>Driveline interference check</i>	20
OPERATION	20
<i>Check-list Before Operation</i>	20
<i>Levelling the Mower</i>	21
<i>Drive Belt Adjustment</i>	22
<i>Starting</i>	22
SERVICE AND MAINTENANCE	22
<i>General Maintenance</i>	22
<i>Gearbox Maintenance</i>	23
<i>PTO Shaft Maintenance</i>	23
<i>Tightening Torque</i>	23
<i>Rotor Flails and Counter Blades Replacement</i>	25
STORAGE & TRANSPORT	25
<i>Storage</i>	25
<i>Transport</i>	25
EXPLODED VIEWS & PARTS LIST	27
WARRANTY	39

SAFETY PRECAUTIONS

Safety Always Comes First

Please be fully aware that you are responsible for the safe operation and maintenance of your wood chipper. YOU must ensure that you and anyone else who is going to operate, maintain or work around the wood chipper is familiar with the operating and maintenance procedures and related safety information contained in this manual. This manual is prepared to guide you through all essential operations related to this wood chipper and alert you to all good safety practices that should be strictly followed.

Please constantly bear in mind that good safety practices not only protect you but also the people around you. Incorporate these practices an inseparable part into your safety program. Be certain that everyone operating this equipment is familiar with the recommended operating and maintenance procedures and follows all the safety precautions. Most accidents can be prevented. Do not risk injury of death by ignoring good safety practices.

General Safety



1. Read and understand the Operator's Manual and all safety signs before using, maintaining, adjusting or cleaning the 3 Point Hitch Wood Chipper.



2. Have a first-aid kit available for use should the need arise and know how to use it.

3. Have a fire extinguisher available for use should the need arise and know how to use it.

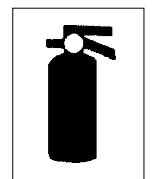

4. Do not allow riders.

5. Wear appropriate protective gear. This list includes but is not limited to:

- A hard hat
- Protective shoes with slip resistant soles
- Protective glasses, goggles or face shield
- Heavy gloves



- Wet weather gear
- Hearing Protection
- Respirator or filter mask

6. Install and secure all guards before starting.



7. Wear suitable ear protection for prolonged exposure to excessive noise.

8. Turn machine off, stop and disable engine, remove ignition key and place in your pocket, set park brake and wait for all moving parts to stop before servicing, adjusting, repairing or unplugging.

9. Clear the area of people, especially small children, before using the unit.

10. Review safety related items annually with all personnel who will operating or maintaining the 3 Point Hitch Wood Chipper.

EQUIPMENT SAFETY GUIDELINES

1. Safety of the operator and bystanders is one of the main concerns in designing and developing equipment. However, every year many accidents occur which could have been avoided by a few seconds of thought and a more careful approach to handling equipment. You, the operator, can avoid many accidents by observing the following precautions in this section. To avoid personal injury or death, study the following precautions and insist those working with you, or for you to follow them.
2. In order to provide a better view, certain photographs or illustrations in this manual may show an assembly with a safety shield removed. However, equipment should never be used in this condition. Keep all shields in place. If shield removal becomes necessary for repairs, replace the shield prior to use.
3. Replace any safety sign or instruction sign that is not readable or is missing. Location of such safety signs is indicated in this manual.
4. Never use alcoholic beverages or drugs which can hinder alertness or coordination while using this equipment. Consult your doctor about using this machine while taking prescription medications.
5. **Under no circumstances should young children be allowed to work with this equipment. Do not allow persons to use or assemble this unit until they have read this manual and have developed a thorough understanding of the safety precautions and of how it works.** Review the safety instructions with all users annually.
6. This equipment is dangerous to children and persons unfamiliar with its operation. The operator should be a responsible, properly trained and physically able person familiar with machinery and trained in this equipment's operations. If the elderly are assisting with work, their physical limitations need to be recognized and accommodated.
7. Never exceed the limits of a piece of machinery. If its ability to do a job, or to do so safely, is in question - **DON'T TRY IT.**
8. Do not modify the equipment in any way. Un- authorized modification may result in serious injury or death and may impair the function and life of the equipment.
9. In addition to the design and configuration of this implement, including Safety Signs and Safety Equipment, hazard control and accident prevention are dependent upon the awareness, concern, prudence, and proper training of personnel involved in the operation, transport, maintenance, and storage of the machine. Refer also to Safety Messages and operation instruction in each of the appropriate sections of the tractor and machine manuals. Pay close attention to the Safety Signs affixed to the tractor and the machine.
10. Install and secure all guards and shields before starting or operating.
11. Keep hands, feet, hair and clothing away from moving parts.
12. Place all controls in neutral, stop tractor engine, set park brake, remove ignition key and wait for all moving parts to stop before servicing, adjusting, repairing, attaching or removing.
13. Place all tractor and machine controls in neutral before starting.
14. Never start or operate machine unless sitting on tractor seat.
15. Clear the area of bystanders, especially small children, as well as animals before starting.

16. Do not put hands or feet under machine while tractor engine or machine is running.
17. Objects can be thrown out from under machine with sufficient force to severely injure people. Stay away from machine when it is running. Keep others away.
18. Always know what you are cutting. Never operate the flail mower in an area that has hidden obstacles. Remove sticks, stones, wire or other objects from working area before starting.
19. Never use the driveline as a step to facilitate work on the machine.
20. Review safety instructions with all operators annually.

Operator safety

1. The minimum age of the operator is regulated by existing national legislation.
2. When shredding wood, the operator must wear protective gloves, protective eyewear, ear protection, safety shoes, dust mask, helmet and long trousers.
3. Hair must be tied above the shoulders. If the operator needs to leave the equipment for any reason, switch this equipment off before leaving.
4. Do not use this equipment indoors, never use a stool, ladder to access the feed hopper if the machine is not switched off.
5. Do not place any part of your body inside the guard.
6. Do not place any part of your body near the muffler when the engine is switched on, even if it is switched off immediately.
7. When using the machine on public roads, observe the safety regulations for road places in force in the country where the machine is used.

Maintenance Safety

1. Good maintenance is your responsibility. Poor maintenance is an invitation to trouble.
2. Follow good shop practices
 - Keep service area clean and dry.
 - Be sure electrical outlets and tools are properly grounded.
 - Use adequate light for the job at hand.
3. Make sure there is plenty of ventilation. Never operate the engine of the towing vehicle in a closed building. The exhaust fumes may cause asphyxiation
4. A fire extinguisher and first aid kit should be kept readily accessible while performing maintenance on this equipment.
4. Be sure electrical outlets and tools are properly grounded.
5. Use adequate light for the job at hand.
6. Before working on this machine, shut off the engine, set the brake, and turn fuel valve off.
7. Keep service area clean and dry.
8. Be sure electrical outlets and tools are properly grounded.
9. Use adequate light for the job at hand.



10. Make sure there is plenty of ventilation. Never operate the engine of the tractor in a closed area. The exhaust gas may cause healthy problem.
11. Before working on this machine, shut off the tractor's engine, set the brakes, and remove the ignition key.
12. Never work under the machine unless it is secured by a mechanical stand.
13. Use personal protection devices such as safety goggles, hand gloves and hearing protectors, when performing any service or maintenance work. Use heavy gloves when handling blades.
14. Only use genuine parts for service and maintenance.
15. A fire extinguisher and first aid kit should be kept readily accessible while performing maintenance on this equipment.
16. Periodically tighten all bolts, nuts and screws and check that all pins are properly installed to ensure unit is in a safe condition.
17. When completing a maintenance or service function, make sure all safety shields and devices are installed before placing machine in service.
18. During the engine start-up period, make sure that all parts of the machine are installed and that all safety devices of the machine are correctly fitted before using the machine.
19. Do not put any material on the feeder until the engine has been started or the engine speed has reached its maximum speed.
20. Do not use the machine for functions other than those for which it was designed.
21. Do not put stones, metal, glass, plastic, soil into the wood chipper and do not remove any protective devices or any attachments while the machine is in operation.
22. Do not reach into rotor or feed hopper openings when the engine is running. Install and secure access covers before starting engine.
23. Keep the working area clean and free of debris to prevent tripping. Operate only on level ground.
24. Do not point discharge at people, animals or buildings. Rotor can expel wood chips fast enough to cause Injury
25. Do not move or transport chipper when the rotor is turning.
26. Do not exceed a safe travel speed when transporting.

HYDRAULIC SAFETY

1. Make sure that all the components in the hydraulic system are kept in good condition and are clean.
2. Before applying pressure to the system, make sure all components are tight, and that lines, hoses and couplings are not damaged.
3. Do not attempt any makeshift repairs to the hydraulic lines, fittings or hoses by using tapes, clamps or cements. The hydraulic system operates under extremely high pressure. Such repairs will fail suddenly and create a hazardous and unsafe condition.
4. Wear proper hand and eye protection when searching for a high pressure hydraulic leak. Use a piece of wood or cardboard as a backstop instead of hands to isolate and identify a leak.
5. If injured by a concentrated high-pressure stream of hydraulic fluid, seek medical attention

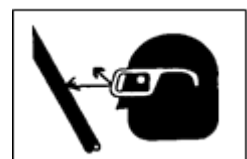

immediately. Serious infection or toxic reaction can develop from hydraulic fluid piercing the skin surface.

6. Relieve pressure on hydraulic system before maintaining or working on system.

SAFETY TRAINING

1. Safety is a primary concern in the design and manufacture of our products. Unfortunately, our efforts to provide safe equipment can be wiped out by a single careless act of an operator or bystander.
2. In addition to the design and configuration of equipment, hazard control and accident prevention are dependent upon the awareness, concern, prudence and proper training of personnel involved in the operation, transport, maintenance and storage of this equipment.
3. It has been said, "The best safety feature is an informed, careful operator." We ask you to be that kind of an operator. It is the operator's responsibility to read and understand ALL Safety and Using instructions in the manual and to follow these. Accidents can be avoided.
4. Working with unfamiliar equipment can lead to careless injuries. Read this manual before assembly or using, to acquaint yourself with the machine. If this machine is used by any person other than yourself, or is loaned or rented, it is the machine owner's responsibility to make certain that the operator, prior to using:
 - a. **Read and understand the operator's manuals.**
 - b. **Is instructed in safe and proper use.**
5. Know your controls and how to stop tractor and machine quickly in an emergency. Read this manual and the one provided with tractor.
6. Train all new personnel and review instructions frequently with existing workers. Be certain only a properly trained and physically able person will use the machinery. A person who has not read and understood all using and safety instructions is not qualified to use the machine. An untrained operator exposes himself and bystanders to possible serious injury or death. If the elderly are assisting with the work, their physical limitations need to be recognized and accommodated.

PREPARATION

1. Never use the machine until you have read and completely understand this manual, the tractor Operator's Manual and each of the Safety Messages found on the safety signs on the tractor and machine.
2. Personal protection equipment including hard hat, safety glasses, safety shoes, and gloves are recommended during assembly, Installation, operation, adjustment, maintaining, repairing, removal, cleaning, or moving the unit. Do not allow long hair, loose fitting clothing or jewellery to be around equipment.
3. **PROLONGED EXPOSURE TO LOUD NOISE MAY CAUSE PERMANENT HEARING LOSS!** Power equipment with or without equipment attached can often be noisy enough to cause permanent, partial hearing loss. We recommend that you wear hearing protection on a full-time basis if the noise in the Operator's position exceeds 80db. Noise over 85db on a long-term basis

can cause severe hearing loss. Noise over 90db adjacent to the Operator over a long-term basis may cause permanent, total hearing loss.

NOTE: Hearing loss from loud noise (from tractors, chain saws, radios, and other such sources close to the ear) is cumulative over a lifetime without hope of natural recovery.

4. Clear working area of stones, branches or hidden obstacles that might be hooked or snagged, causing injury or damage.
5. Use only in daylight or good artificial light.
6. Be sure machine is properly mounted, adjusted and in good operating condition.
7. Ensure that all safety shielding and safety signs are properly installed and in good condition.

TRANSPORT SAFETY







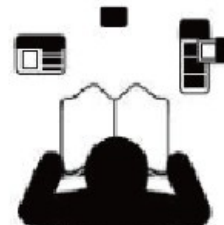
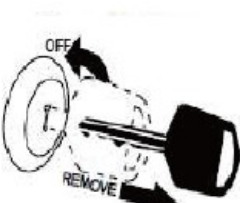
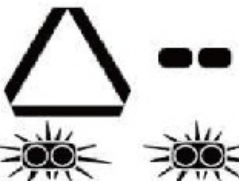

1. Comply with state and local laws governing safety and transporting of machinery on public roads.
2. Check that all the lights, reflectors and other lighting requirements are installed and in good working condition.
3. Do not exceed a safe travel speed. Slow down for rough terrain and cornering.
4. Fold up and secure feed hopper before moving or transporting.
5. Be sure the machine is hitched positively to the tractor and a retainer is used through the mounting pins.
6. Do not drink and drive.
7. Be a safe and courteous driver. Always yield to oncoming traffic in all situations, including narrow bridges, intersections, etc. Watch for traffic when operating near or crossing road- ways.
8. Never allow riders on the machine.

Storage Safety

1. Store the machine in an area away from human activity. Do keep the machine out of the children's reach. Do not permit children to play on or around the stored machine.
2. Store the machine in a dry, level area.
3. Clean grease and oil as required and protect it from the elements.

Safety Signs and Model Decals

Safety signs

<p>For Your Protection</p> <ul style="list-style-type: none"> ▲ Thoroughly read and understand the Safety Symbols and read all the instructions noted on them. 	<p>Shutdown and Storage</p> <ul style="list-style-type: none"> ▲ Lower machine to ground, put tractor in Park, turn off the engine, and remove the key. ▲ Detach and store implement in an area where children normally do not play. Secure implement by using blocks and supports. 	<p>Use Safety Lights & Devices</p> <ul style="list-style-type: none"> ▲ Slow moving tractors, self-propelled equipment, and towed implements can create a hazard when driven on public roads. They are difficult to see, especially at night. ▲ Flashing warning lights and turn signals are recommended whenever driving on public roads. 	<p>Wear Protective Equipment</p> <ul style="list-style-type: none"> ▲ Wear protective clothing and equipment appropriate for the job. Avoid loose clothing or hair. ▲ Prolonged exposure to loud noise can cause hear impairment or hearing loss. Wear suitable hearing protection such as earmuffs or earplugs. ▲ Operating equipment safely requires the full attention of the operator. Avoid wearing radio headphones while operating machinery. 	<p>Practice Safe Maintenance</p> <ul style="list-style-type: none"> ▲ Understand procedures before doing work. Use proper tools and equipment. ▲ Work in a clean and dry area. ▲ Lower the implement to the ground, put tractor in park, turn off engine and remove the key before doing the maintenance. ▲ Allow the implement to cool completely. ▲ Do not grease the implement while it's in operation. ▲ Inspect all parts. Make sure all parts are in good shape and installed properly. ▲ Remove buildup of grease, oil or debris. ▲ Remove all tools and unused parts before operation. 
<p>Tire Safety</p> <ul style="list-style-type: none"> ▲ Tire chaning can be dangerous and should be performed by trained personnel using the correct tools and equipment. ▲ When inflating tires, use a clip-on chuck and extension hose long enough to allow you to stand to one side and NOT in front of or over the tire assembly. Use a safety cage if available. ▲ When removing and installing wheels, use wheel handling equipment adequate for the weight load. 	<p>Prepare for Emergencies</p> <ul style="list-style-type: none"> ▲ Be prepared for fire outbreak ▲ Keep a first aid kit and fire extinguisher handy. ▲ Keep emergency numbers for doctor, ambulance, hospital and fire department near phone. 	<p>Keep Riders Off Machinery</p> <ul style="list-style-type: none"> ▲ Riders obstruct the operator's view. They could be struck by foreign objects or thrown from the machine. ▲ Never allow children to operate the equipment. 	<p>Avoid HP Fluids Hazard</p> <ul style="list-style-type: none"> ▲ Escaping fluid under pressure can penetrate the skin causing serious injury. ▲ Avoid the hazard by relieving pressure before disconnecting hydraulic lines or performing work on the system. ▲ Make sure all hydraulic fluid connections are tight and all hydraulic hoses and lines are in good condition before applying pressure to the system. ▲ Use a piece of paper or carboard, NOT BODY PARTS, to check for suspected leaks. ▲ Wear protective gloves and safety glasses or goggles when working with hydraulic systems. ▲ If an accident occurs, see a doctor immediately. Any fluid injected into the skin must be treated within a few hours or gangrene ny happen. 	 <p>DANGER Neglect the safety precautions may cause critical injury or death.</p> <p>WARNING Incorrect operation or service of the machine may cause damage to the machine or serious personal injury.</p> <p>CAUTION Incorrect operation or servicing of</p>

Safety decals

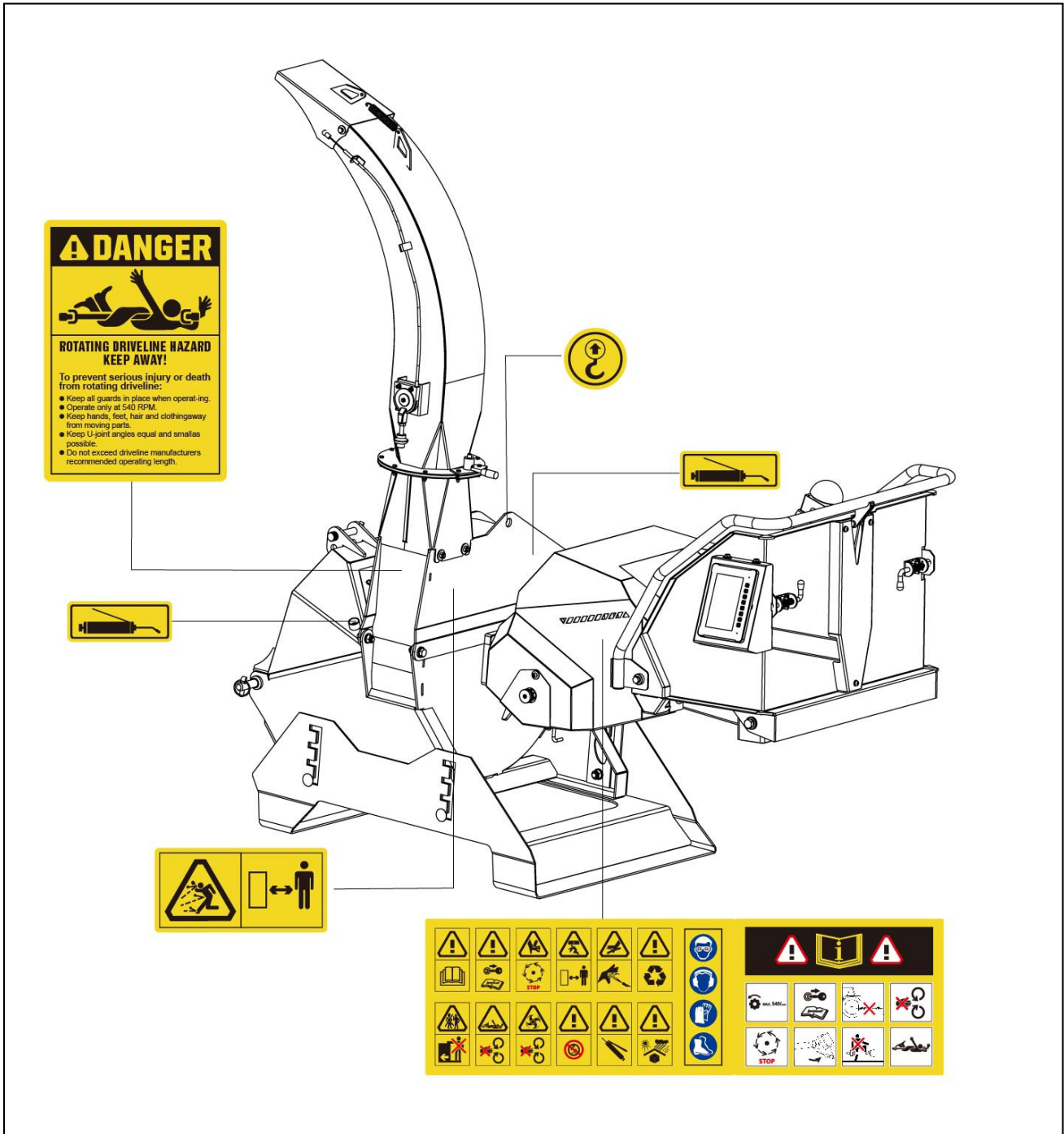



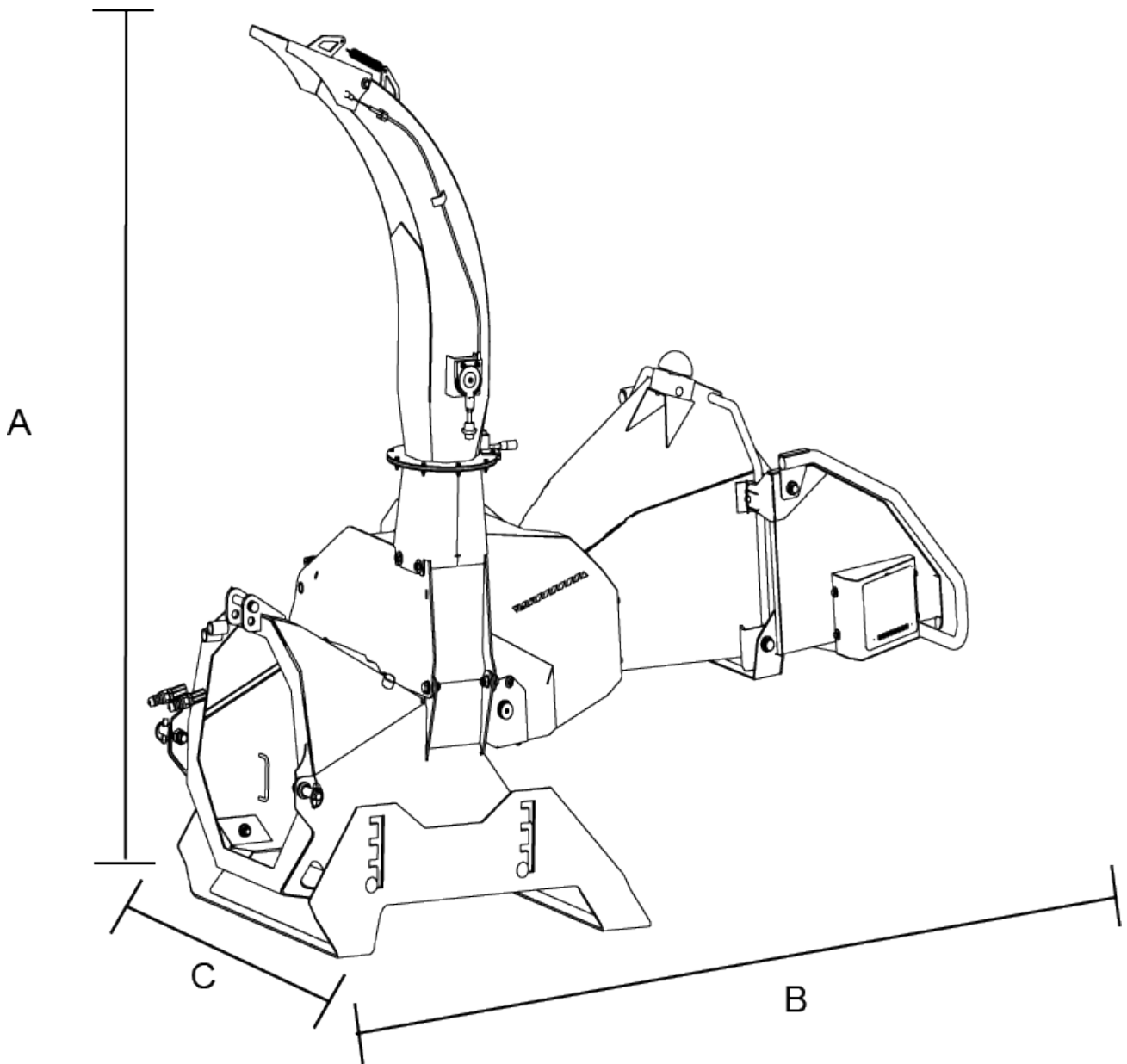

PRODUCT SPECIFICATION

Implement Specification



	Model		WCEP150
Parameters	A	mm	2245
	B		2150
	C		1130

Max dia. of wood chips	mm	150mm-6"
Hourly production	m ³	8 -13 m³
Dia of flywheel	mm	680mm - 27"
Thickness of flywheel		24mm-1"
Height of discharge hood		2050mm - 81"
Chipper Housing Opening		150mmx202mm (6" x 8")
Chipper Hopper Opening		550mmx755mm (22" x 30")
Feeding Style		Self-feeding
	PTO Height	510mm-660mm (20"-26")
	No. of Knives on flywheel	4
	Hydraulic Flow	3 - 6 gpm (12 - 23 lpm)
	CAT.	CAT I/CAT II
	HP/KW	30KW/75HP-40 KW /100HP
	weight	440kg / 976lbs

Implement Identification

An Identification plate is affixed to the frame of each implement. It contains the "CE" Certification brand and information about: the Manufacturer, Type, Serial Number, Model Number, Weight, The nameplate on the right is for reference only and is based on the real thing.



UNPACKING

After unpacking, please check the components shown in **Figure 1**.

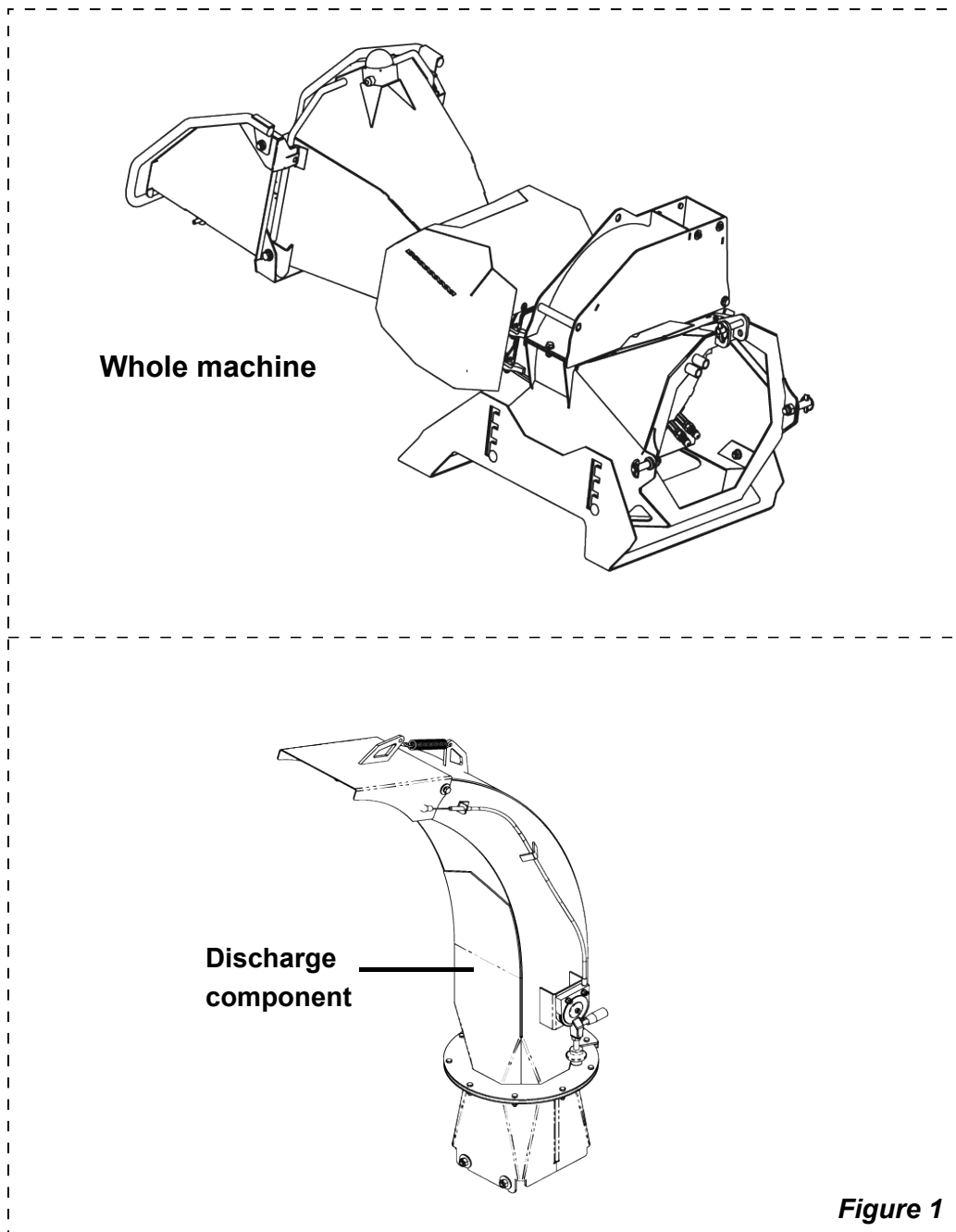
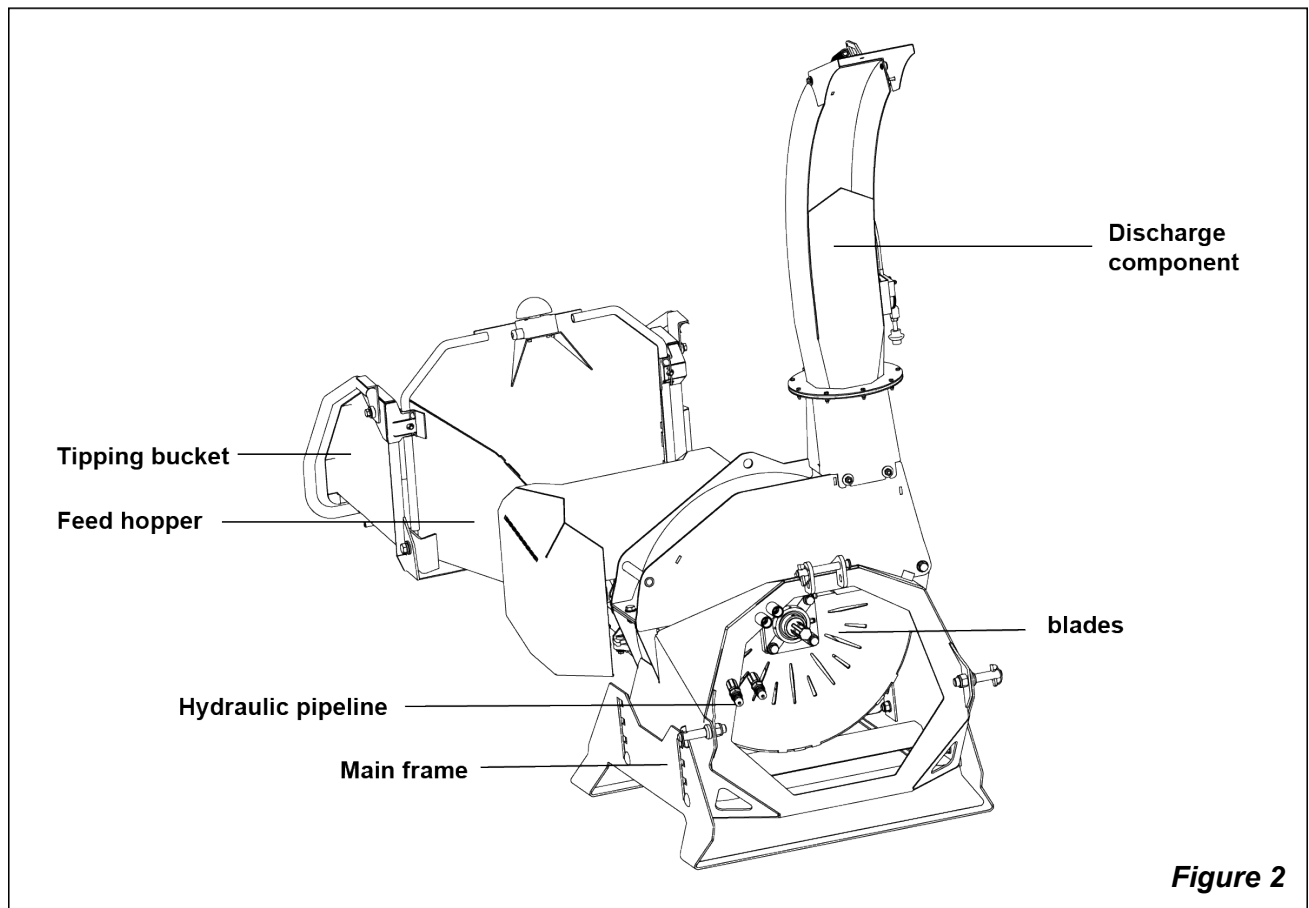

Figure 1

PRODUCT OVERVIEW

See Figure 2

Congratulations on your purchase of the Three Point Suspension Rear PTO Drive Closed Bucket Hydraulic Feed Wood Chipper. This machine is specifically designed and built to meet the unique demands of the timber and landscaping industry.



ASSEMBLY & SET-UP

Discharge Assembly

CAUTION

- Follow tractor shut-down procedures provided in tractor manual.
- Tractor horsepower and hitch category should be within the required range. The lower 3-Point arms must be stabilized to prevent side-to-side movement.

Note: Please have a hoist or any equivalent lifting equipment ready for the assembly work.

Follow the assembly order as below: Discharge Assembly

See *Figure 3*

1. Secure the assembly with locknut, washers and nuts;
2. Tighten all the bolts to correct torque.

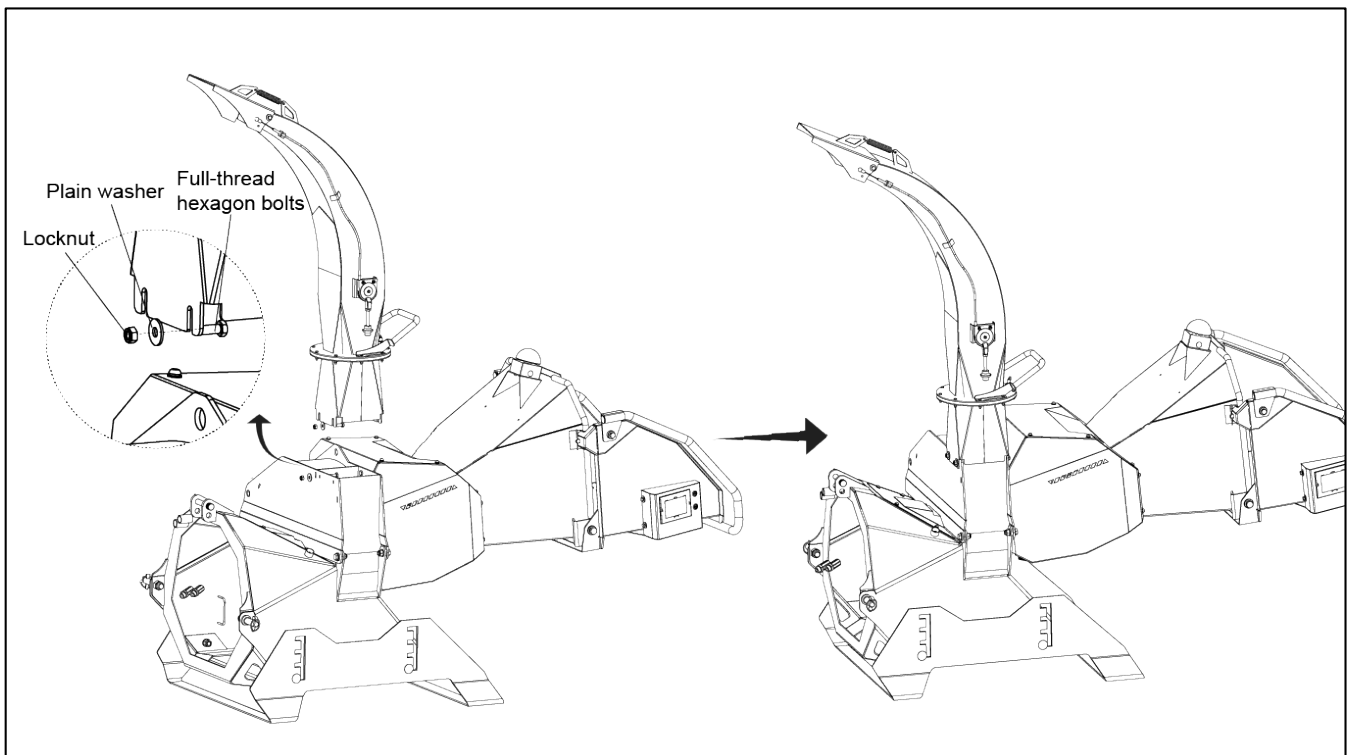

Note: Pay attentions to washers and nuts of different sizes used here.

Tractor Hook-up

WARNING

- A crushing hazard exists while hooking-up and unhooking the implement. Keep people and animals away while approaching the implement or pulling away from the implement. Do not operate hydraulic controls while a person or an animal is nearby.
- Always follow “Tractor Shutdown Procedure” provided in tractor manual.
- Tractor horsepower and hitch category should be within the required range. The lower 3-Point arms must be stabilized to prevent side-to-side movement.

Note:

- This chipper is featured with a hitch design compatible with CAT.I and CAT. II. It can be attached to both the front and rear of a tractor. Attaching a chipper to the front of a tractor typically follows a similar process to attaching it to the rear, although there may be some differences based on the specific tractor. Make sure the chipper is compatible with your tractor's front-end attachment system.
- There are one pair of extra hitch pins delivered at your disposal.
- The draw bar should be checked for clearance when the chipper is attached for the first time. Move drawbar ahead or remove if it interferes.

See Figure 4

1. Remove Pin (#4), Hanging on the pin (#5), Locknuts (#2), pins (#1) and hitch pins (#3).
2. Adjust the top link of the three-point hitch system on the tractor to match the height of the top link attachment point on the chipper. This helps ensure that the chipper is level when attached;
3. Attach tractor's top center link and secure with pins accordingly:

Attach tractor to the chipper:

Upper Hook-Up:

- a. Attach lower 3-point arms to the upper center hitch clevises with hitch pins (#4) and secure with Hanging on the pin (#5).

Lower Hook-Up:

- b. Attach center 3-point link to the lower hitch clevis with pins (#1) and secure with Locknuts (#2).and hitch pins(#3)

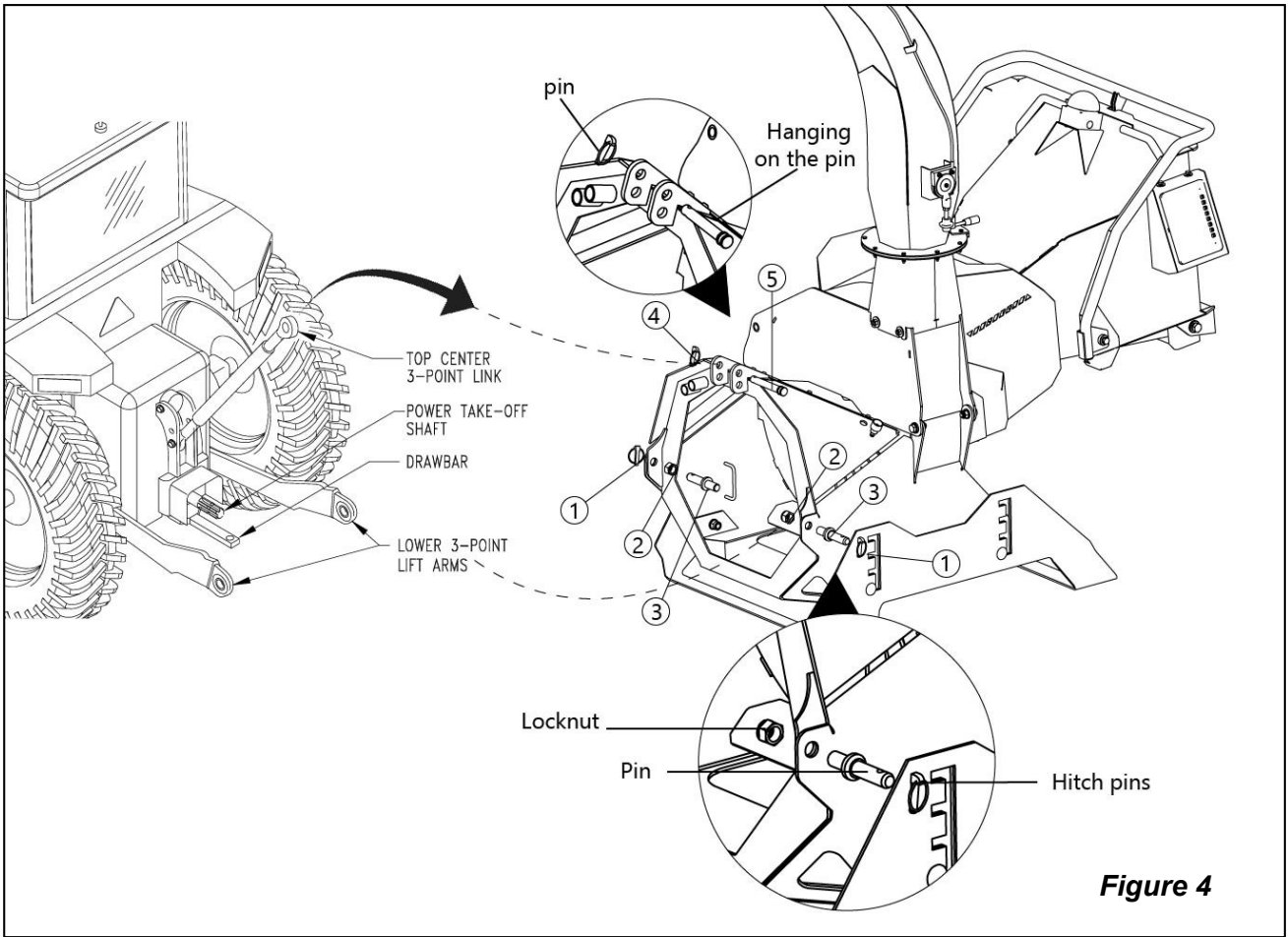

Figure 4

Driveline Installation

DANGER

- Do not engage tractor PTO while hooking-up and unhooking the prop shaft or stand near a rotating prop shaft. A person's body and/or clothing may get entangled to cause severe injury.
- Do not use a power take-off adapter. The adapter will increase strain on the tractor's power take-off shaft causing possible damage to shaft and driveline. It will also defeat the purpose of the tractor's power take-off shield.
- Make certain driveline yokes are securely fastened at each end. A loose yoke can work free allowing the driveline to rotate uncontrollably.

Note: There are 3 types of PTO shafts available.

See Figure 5

Type A shaft has interchangeable ends for installation;

Type B shaft shall have the end where safety pin locates connected with the implement;

Type C shaft shall have end where the clutch locates connected with the implement.

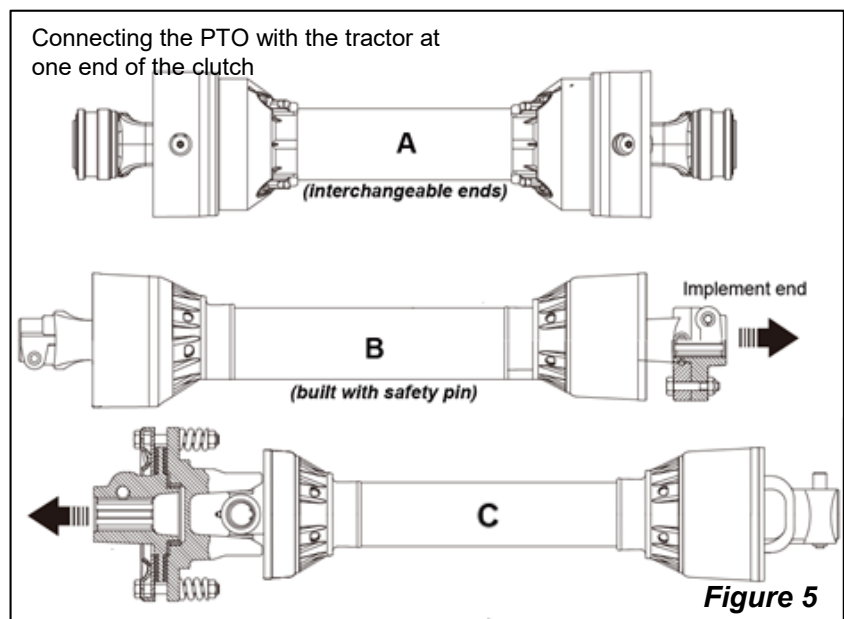

1. Park the tractor on a level surface. Slowly engage the tractor's 3-point lifting lever to lift the chipper until it is aligned (horizontal) with the tractor PTO shaft.
2. Support chippers deck at this height with support jacks or blocks to keep chippers from drifting down.
3. Place gear selector in park, set park brake, shut tractor off, and remove switch key.
4. Slide outer yoke of driveline over the tractor PTO shaft. Secure driveline with yoke locking device
5. If the driveline is too long and does not fit tractor, skip to "**Customize driveline**" to shorten the driveline.
6. The driveline should now be moved back and forth to ensure secured connection at both ends. Reattach any end that is loose. Go to "**Driveline length check**" below to ensure proper accommodation.
7. Hook driveline safety chain on the tractor end of driveline to the tractor. Re-latch safety chain to the driveline shield.

- Hook driveline safety chain on the chippers end of driveline to the chippers frame. Re-latch safety chain to the driveline shield.

Driveline length check

Before operating the chipper, ensure that the size of driveshaft is adequate. The driveshaft supplied with the machine has a standard length, therefore it may need an adaptation of the length, depending of the tractor which the chipper is attached with.

Maximum compressed position

The power take-off shaft input shaft must be aligned and level with each other when checking driveline minimum length. A driveline that is too long can damage tractor and implement.

See **Figure 6**

Hold inner and outer drivelines parallel to each other as shown and measure distance **L1**:

- If **L1** is less than 1" (2.5 cm), skip to "**Customize driveline**" to shorten the driveline.
- If **L1** is greater than or equal to 1" (2.5 cm), skip to "**Maximum extended position**" below.

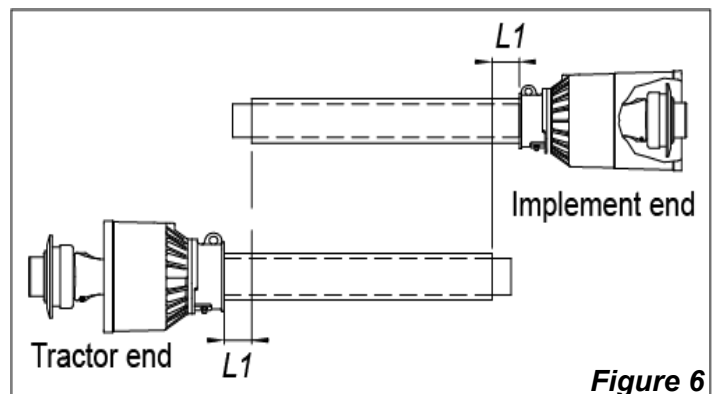

Figure 6

Maximum extended position

See **Figure 7**

The driveline maximum allowable length must, when fully extended, have a minimum overlap (**L2**) of profile tubes by not less than 1/3 the free length with both inner and outer profile tubes being of equal length.

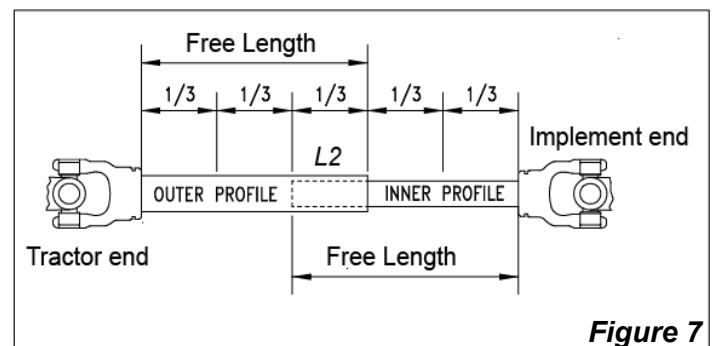

Figure 7

Customize driveline

See **Figure 8**

- Un-hook driveline from tractor PTO shaft and pull outer and inner drivelines apart.
- Re-attach outer driveline to tractor PTO shaft. Pull on inner and outer drivelines to be sure universal joints are properly secured.
- Hold inner and outer

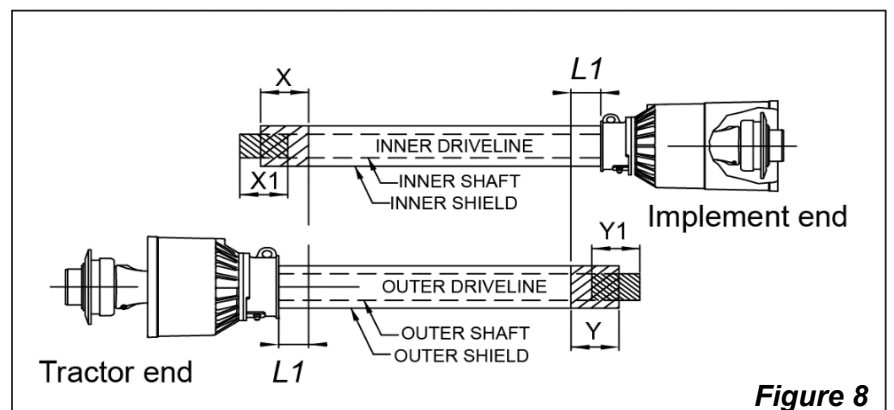

Figure 8

drivelines parallel to each other:

- a. Measure 1" (2.5 cm) ("**L1**" dimension) back from outer driveline universal joint shield and make a mark at this location on the inner driveline shield.
 - b. Measure 1"(2.5 cm) ("**L1**" dimension) back from the inner driveline universal joint shield and make a mark at this location on the outer driveline shield.
4. Remove driveline from tractor .
 5. Measure from end of inner shield to scribed mark ("X" dimension). Cut off inner shield at the mark. Cut same amount off the inner shaft ("X1" dimension).
 6. Measure from end of outer shield to scribed mark ("Y" dimension). Cut off outer shield at the mark. Cut same amount off the outer shaft ("Y1" dimension).
 7. Remove all burrs and cuttings.
 8. Apply multi-purpose grease to the inside of the outer shaft and reassemble the driveline

Driveline interference check

See Figure 9

Slowly engage tractor 3-Point control lever to lower chippers while checking for sufficient drawbar clearance. Move drawbar ahead, aside, or remove if required.

1. Raise and lower implement to find maximum extended driveline length. Check to make certain the driveline does not exceed the maximum allowable length and 25° up or down.
2. If needed, set tractor 3-Point lift height to keep driveline from exceeding the maximum allowable length and 25° up or down.

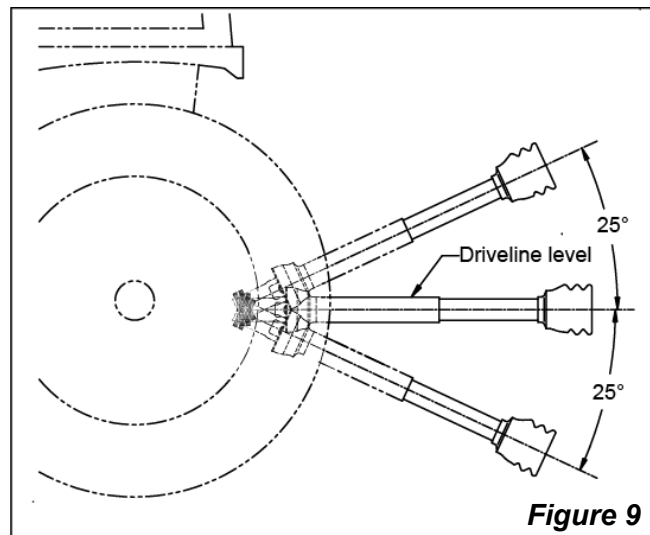

Figure 9

OPERATION

Check-list Before Operation

CAUTION

- Hazard control and accident prevention are dependent upon the awareness, concern, prudence, and proper training involved in the operation, transport, storage, and maintenance of the chipper. Therefore, it is absolutely essential that no one operates the machine without first having read, fully understood, and become totally familiar with the Operator's Manual. Make sure the operator has completed the Checklist below.

Before operating the machine, the following areas should be checked off:

1. Before starting up the machine, check and lubricate all grease points, on the machine and drive shaft.
2. Use only an agricultural tractor with horsepower within limits of the implement.
3. Check that the machine is properly attached to the tractor. Be sure retainers are used on the mounting pins.
4. Be sure extra weights are mounted on the front of the tractor, if required.
5. Check that the tractor PTO shaft turns freely and that the machine driving shaft can telescope easily.
6. Check the blades. Be sure they are not damaged or broken and swing freely in their mount. Repair or replace as required.
7. Check and tighten the blade bolts.
8. Check for entangled material in all rotating parts. Remove this material.
9. Install and secure all guards, doors and covers before starting.
10. Before installing the PTO ensure the engine is stopped and the PTO shaft is in safe working order.
11. All other people shall leave the area before connecting the driving power from the tractor.
12. Before cleaning, repairing and lubricating the machine, stop the motor and take the key away with you.
13. When the PTO shaft is not connected with the tractor, support it through the frame to protect it from lying in the dirt.
14. Don't approach the machine when it is operating.

Levelling the Mower

Level adjustments are made at the tractor's 3-Point lower arms and top center link.

1. Park tractor and chippers on a flat level surface.
2. Slowly raise chippers with the tractor's Hydraulic 3-Point lift until the unit is about 1 to 2" above the ground.
3. Ensure that the lower arms are stabilized to prevent excessive side movement.
4. Place a spirit level on the top cover running from left to right and adjust one of the lower 3-Point arms up or down until the chippers is level from left to right.
5. Adjust tractor's top center link to place the upper hitch pin vertically above or slightly behind the lower hitch pins.
6. Slowly operate the tractor's 3-Point hydraulic control up and down to check for clearance between the tires, frame, drawbar, etc.
1. ground will wear quickly. If necessary, readjust cutting height to keep blades from touching the ground.

Drive Belt Adjustment

WARNING

- Excessive tension on the belt may lead to premature failure of belt and drive components. Excessive tension on the belt may also lead to a safety hazard to the operator or bystanders.

See Figure 13

The Belt tension should be checked after the first 20 hours of use and every 40 hours thereafter.

1. Check belt tension by applying approximately 22 pounds of pressure half way between the pulleys. The belt should deflect approximately 3/8".
2. If the belt deflection is out of the recommended range, adjust the belt tension as below:
 - Loosen the bolts, split lock washers and common washers to remove the belt guard;
 - Loosen the jamb nut;
 - Turn the adjusting nut until desired belt tension is achieved;
 - Tighten the jamb nut;
 - Put back the belt guard by tightening the removed bolts and washers.

Starting

Before starting the machine, check and adjust the following items:

1. Drive belt tension.
2. Grease nipples on bearings and PTO shaft.
3. All bolts, nuts and screws.

SERVICE AND MAINTENANCE

General Maintenance

The period recommended is based on normal operating conditions. Severe or unusual conditions may require more frequent maintenance.

Each 4 hours of work:

Check and tighten nuts and bolts.

Grease with lithium based grease when it is indicated by the symbol GREASE.







PTO Shaft Maintenance

It is recommended to lubricate the PTO shaft with multi-purpose grease after every 8 to 10 hours of use or at least once a day during heavy use. The PTO shaft is designed to telescope to allow for dimensional changes as the machine goes through its operating range. A tubular guard encloses the driving components and is designed to turn relative to the driving components. The shaft should telescope easily and the guard turn freely on the shaft at all times. Annual disassembly, cleaning and lubrication is recommended to insure that all components function as intended. To maintain the shaft, follow this procedure:

1. Remove the shaft from the machine.
2. Pull shaft apart.
3. Use a screwdriver to pry the tabs out of the sleeves on each end.
4. Pull the shaft out of the plastic tubular guard.
5. Use a solvent to clean the male and female portions of the telescoping ends.
6. Apply a light coat of grease to each end.
7. Clean the grooves on each end where the tabs are located. Clean each tab also.
8. Apply a light coat of grease to each groove.
9. Insert the shaft into its respective guard and align the slots with the groove.
10. Insert the tabs through the slots and seat in the groove.
11. Check that each guard turns freely on the shaft.
12. Assemble the shaft.
13. Check that the shaft telescopes easily.
14. Replace any components that are damaged or worn.
15. Install the shaft on the machine.

Tightening Torque

Please follow the table below to identify the torque value as required.

Torque Values Chart for Common Bolt Sizes													
Bolt Size (inches)	Bolt Head Identification							Bolt Head Identification					
	 Grade 2		 Grade 5		 Grade 8		Bolt Size (Metric)	 Class 5.8		 Class 8.8		 Class 10.9	
in-tpi ¹	N · m ²	ft-lb ³	N · m	ft-lb	N · m	ft-lb	mm x pitch ⁴	N · m	ft-lb	N · m	ft-lb	N · m	ft-lb
1/4" - 20	7.4	5.6	11	8	16	12	M 5 X 0.8	4	3	6	5	9	7
1/4" - 28	8.5	6	13	10	18	14	M 6 X 1	7	5	11	8	15	11
5/16" - 18	15	11	24	17	33	25	M 8 X 1.25	17	12	26	19	36	27
5/16" - 24	17	13	26	19	37	27	M 8 X 1	18	13	28	21	39	29
3/8" - 16	27	20	42	31	59	44	M10 X 1.5	33	24	52	39	72	53
3/8" - 24	31	22	47	35	67	49	M10 X 0.75	39	29	61	45	85	62
7/16" - 14	43	32	67	49	95	70	M12 X 1.75	58	42	91	67	125	93
7/16" - 20	49	36	75	55	105	78	M12 X 1.5	60	44	95	70	130	97
1/2" - 13	66	49	105	76	145	105	M12 X 1	90	66	105	77	145	105
1/2" - 20	75	55	115	85	165	120	M14 X 2	92	68	145	105	200	150
9/16" - 12	95	70	150	110	210	155	M14 X 1.5	99	73	155	115	215	160
9/16" - 18	105	79	165	120	235	170	M16 X 2	145	105	225	165	315	230
5/8" - 11	130	97	205	150	285	210	M16 X 1.5	155	115	240	180	335	245
5/8" - 18	150	110	230	170	325	240	M18 X 2.5	195	145	310	230	405	300
3/4" - 10	235	170	360	265	510	375	M18 X 1.5	220	165	350	260	485	355
3/4" - 16	260	190	405	295	570	420	M20 X 2.5	280	205	440	325	610	450
7/8" - 9	225	165	585	430	820	605	M20 X 1.5	310	230	650	480	900	665
7/8" - 14	250	185	640	475	905	670	M24 X 3	480	355	760	560	1050	780
1" - 8	340	250	875	645	1230	910	M24 X 2	525	390	830	610	1150	845
1" - 12	370	275	955	705	1350	995	M30 X 3.5	960	705	1510	1120	2100	1550
1-1/8" - 7	480	355	1080	795	1750	1290	M30 X 2	1060	785	1680	1240	2320	1710
1-1/8" - 12	540	395	1210	890	1960	1440	M36 X 3.5	1730	1270	2650	1950	3660	2700
1-1/4" - 7	680	500	1520	1120	2460	1820	M36 X 2	1880	1380	2960	2190	4100	3220
1-1/4" - 12	750	555	1680	1240	2730	2010							
1-3/8" - 6	890	655	1990	1470	3230	2380							
1-3/8" - 12	1010	745	2270	1670	3680	2710							
1-1/2" - 6	1180	870	2640	1950	4290	3160							
1-1/2" - 12	1330	980	2970	2190	4820	3560							

¹ in-tpi = nominal thread diameter in inches-threads per inch
² N · m = newton-meters
³ ft-lb = foot pounds
⁴ mm x pitch = nominal thread diameter in millimeters x thread pitch

Torque tolerance + 0%, -15% of torquing values. Unless otherwise specified use torque values listed above.
All locknuts or lubricated fasteners: Use 75% of torque value. (i.e. 1/2"-13 GR5 = 76 ft-lb; 75% of 76 or .75 x 76 = 57 ft-lb)

Rotor Flails and Counter Blades Replacement

WARNING

- To avoid serious injury or death, the power take-off must be disengaged, tractor engine turned off, and switch key removed before doing work underneath the machine. Wear heavy gloves and all necessary protections while replacing the blades.

Frequently check rotor blades and static blades to make sure they are in good working condition and properly secured. Replace worn or damaged parts with new blades. Make sure that the replacement of blade in the same weight to guarantee a balance of rotor spinning. The replaced blade must be the original factory accessories.

STORAGE & TRANSPORT

Storage

1. Remove any dirt and grease that may have accumulated on the mower and moving parts. Scrape off compacted dirt from under the hood. Clean the machine inside and out so as to avoid corrosion.
2. Check rotor, blades, blade mounts, and blade bolts for wear and replace if necessary.
3. Don't spray water on the rolling bearing if you clean the machine with high pressure sprayer.
4. Check and clean the universal joint, driving belt press roller, or replace them if they are not in good condition. Lubricate wherever needed.
5. Recoat the parts rubbed and damaged for anti-corrosion.
6. Store the machine in a dry, level area.

Transport

WARNING

- Always disengage power take-off before raising mower to transport position.
- When traveling on roadways, travel in such a way that other vehicles may pass you safely. Always use LED lights, clean reflectors, and a slow moving vehicle sign that is visible from the back to warn operators in other vehicles of your presence.
- Always comply with all federal, state, and local laws.

1. When raising chippers to transport position, be sure driveline does not contact tractor or chipper. If needed, adjust and set tractor 3-point lift height to limit chipper movement and to protect driveline.
2. Be sure to reduce tractor ground speed when turning, leaving enough clearance so that the chipper does not contact obstacles such as buildings, trees, fences, etc.

3. Select a safe ground travel speed when transporting from one area to another. When traveling on roadways, transport in such a way that faster moving vehicles may pass safely.
4. When traveling over rough or hilly terrain, shift tractor to a lower gear

Troubleshooting

FAILURE	POSSIBLE CAUSES	SOLUTION
Rotor does not turn.	Obstructed discharge.	Clear debris from discharge chute
	Rotor plugged.	Inspect and clear chipper hopper, lower rotor housing, and rotor
Slow feeding.	Low engine speed.	Adjust the throttle valve
	Rotor blades or ledger knife are dull.	Rotate, sharpen or replace blade or knives.
	Rotor blade angle wrong, improper angle.	Re-sharpen knives to specified angle and check that blade is installed properly.
	Obstructed discharge.	Clear debris from discharge chute
Unusual vibration while running.	Broken or missing blade.	Replace broken/missing blade.
	Rotor may be bent.	Invert first and spit out the broken wood
Machine requires excessive power or stalls.	Obstructed discharge.	Clear debris from discharge chute .
	Feeding in too much material.	Feed smaller amounts into chipper hopper.
	Feeding material too quickly	Feed larger material slowly into chipper hopper.
	Rotor plugged.	Inspect and clear chipper hopper lower rotor housing and rotor.
	Green material does not discharge.	Allow material to dry or alternate dry/wet material.
	Chipper blade clearance too large.	Set clearance between rotor blade and ledger knife.
	Dull blades.	Rotate, sharpen or replace blades

EXPLODED VIEWS & PARTS LIST

BRAWN CHIPPER

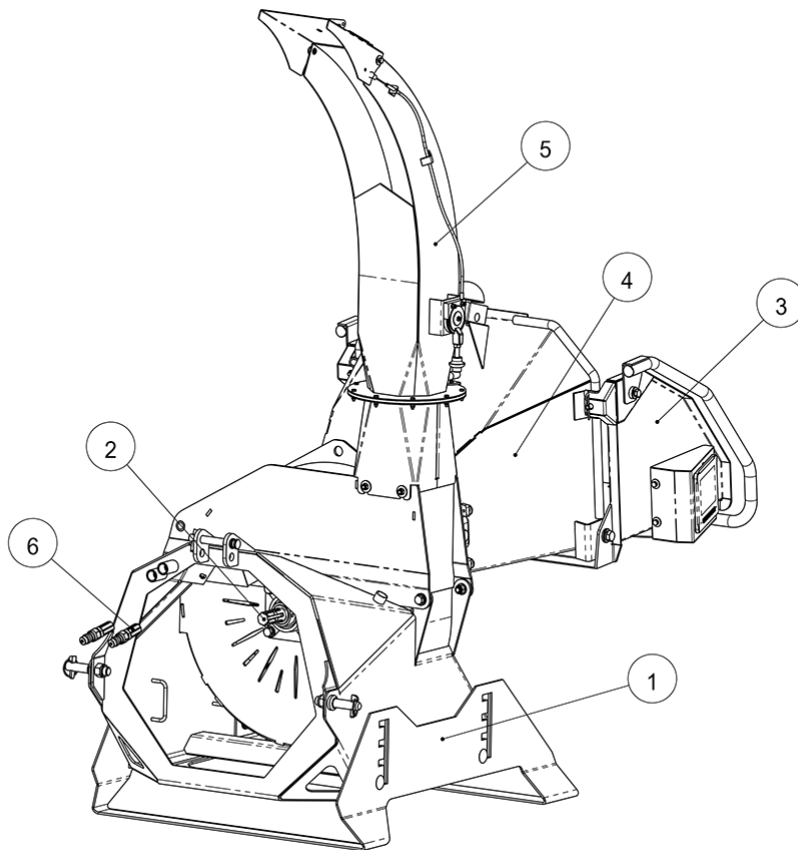

POS.	COD.	Specification	Description	Qty
1	2060107308	W01017A01000-000	Main frame	1
2	2060107309	W01017A02000-000	Knife disc assembly	1
3	2060107307	W01017A03000-000	Tipping bucket	1
4	2060107306	W01017A05000-000	Feed hopper	1
5	2060107311	W01017A06000-000	Discharge component	1
6	2060107310	W01017A55000-000	Hydraulic pipeline	1

FEED HOPPER WELDING

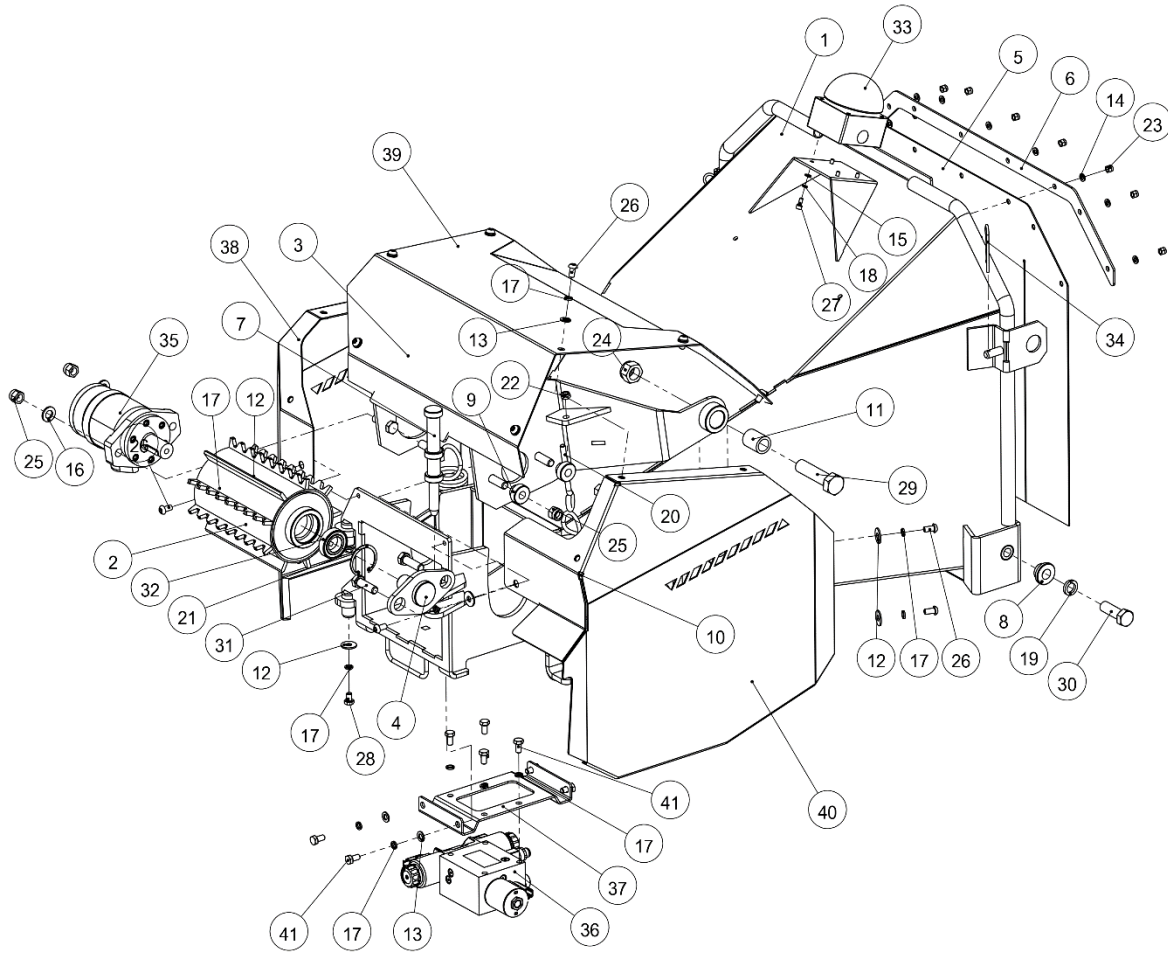

POS.	COD.	Specification	Description	Qty
1	2020007250	W01017A05400-000	Feed hopper welding	1
2	2020007251	W01017A05300-000	Roller	1
3	2020007246	W01017A05200-000	Roller frame	1
4	2020007252	W01017A05100-000	Roller shaft	1
5	3210300632	W01017A05000-006	Check curtain	1
6	2000006142	W01017A05000-005	Platen	1
7	2010005736	W01017A05000-004	Lock Axis	1
8	2010005735	W01017A05000-003	Spacer sleeve	2
9	2010005734	W01017A05000-001	Spacer sleeve	2
10	3110100006	L II -6×45×176×15-R-65Mn-EP_Zn	Tension spring	2
11	3100900618	JDB-1-20×28×35	JDB	2
12	3080200008	GB/T96.2-8-EP•Zn	Large plain washer	8

13	3080100004	GB/T95-8-EP•Zn	Plain washer	12
14	3080100003	GB/T95-6-EP•Zn	Plain washer	8
15	3080100002	GB/T95-5-EP•Zn	Plain washer	4
16	3080100007	GB/T95-12-EP•Zn	Plain washer	2
17	3080500007	GB/T93-8-EP•Zn	Spring washer	24
18	3080500005	GB/T93-5-EP•Zn	Spring washer	4
19	3080500011	GB/T93-16-EP•Zn	Spring washer	2
20	3041600602	GB/T896- M8×50 (Φ13.5-90) - 4.6-EP•Zn	Eye Bolt	2
21	3080600030	GB/T893-47-A	Retaining rings for borP	1
22	3050500003	GB/T889.1-M8-8-EP•Zn	Locknut	2
23	3050500002	GB/T889.1-M6-8-EP•Zn	Locknut	8
24	3050500011	GB/T889.1-M20-8-EP•Zn	Locknut	2
25	3050500007	GB/T889.1-M12-8-EP•Zn	Locknut	4
26	3060300003	GB/T70.2-M8×16-8.8-EP•Zn	Hexagon socket button head screws	15
27	3060100003	GB/T70.1-M5×12-8.8-EP•Zn	Hexagon socket head cap screws	4
28	3040100020	GB/T5783-M8×12-8.8-EP•Zn	Full-thread hexagon bolts	2
29	3040100140	GB/T5783-M20×80- 8.8-EP•Zn	Full-thread hexagon bolts	2
30	3040100108	GB/T5783-M16×50- 8.8-EP•Zn	Full-thread hexagon bolts	2
31	3040100071	GB/T5783-M12×40- 8.8-EP•Zn	Full-thread hexagon bolts	4
32	3100100031	GB/T 276-94-6005- 2RZ	Deep groove ball bearing	1
33	3190200638	EFAK-RV/KC11/IY	Emergency stop	1
34	3120400008	Din11024-4-EP•Zn	R Pin	2
35	3181000008	155160A6910AAATH	Hydraulic motor	1
36	3180700694	DPH-0942-23	Hydraulic Valve	1
37	2000006272	W01017A05000-007	Solenoid valve mounting plate	1
38	2020007470	W01017A05600-000	Right side weldment	1
39	2020007471	W01017A05700-000	Top weldment	1
40	2020007472	W01017A05800-000	Left side weldment	1
41	3040100021	GB/T5783-M8×16-8.8- EP•Zn	Full-thread hexagon bolts	8

KNIFE DISC ASSEMBLY

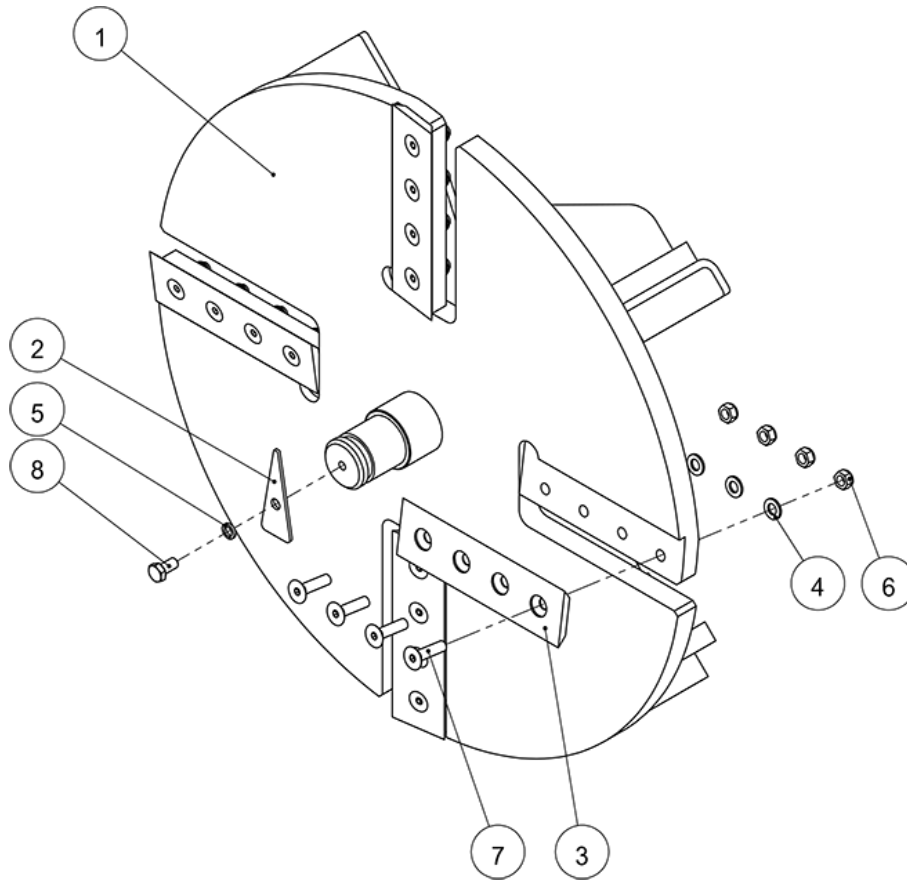

POS.	COD.	Specification	Description	Qty
1	2020007257	W01017A02100-000	Rotor	1
2	2000006147	W01017A02000-001	Induction gasket	1
3	3220100007	MT21001	Blade	4
4	3080100006	GB/T95-10-EP•Zn	Plain washer	16
5	3080500008	GB/T93-10-EP•Zn	Spring washer	1
6	3050500004	GB/T889.1-M10-8-EP•Zn	Locknut	16
7	3060200036	GB/T70.3-M10×40- 8.8-EP•Zn	HSCS-Countersunk	16
8	3040100041	GB/T5783-M10×20- 8.8-EP•Zn	Full-thread hexagon bolts	1

TIPPER ASSEMBLY

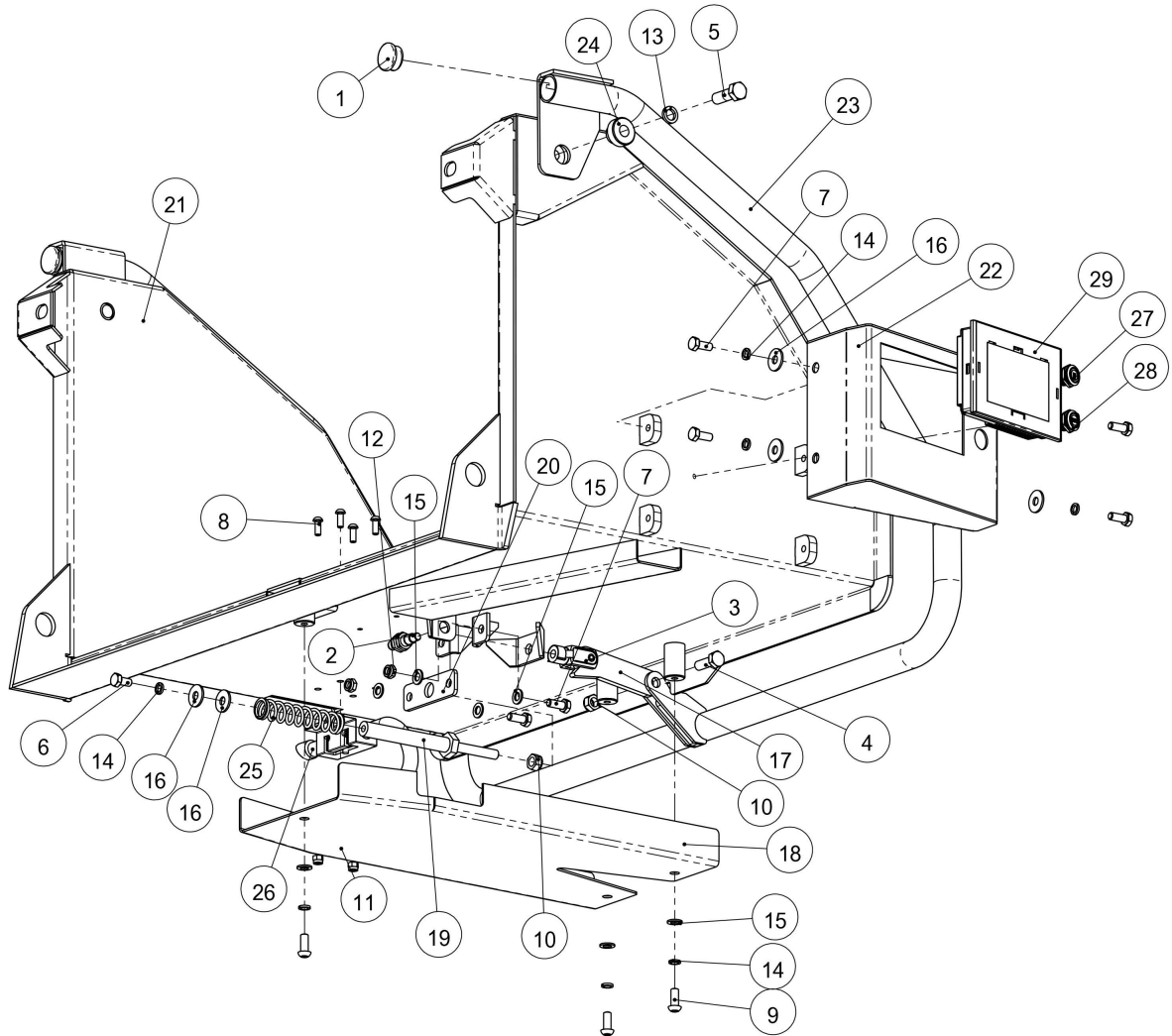

POS.	COD.	Specification	Description	Qty
1	3210200002	30x2	Pipe Plug	2
2	3191000615	E2B-M12KN05-WZ	Proximity switch	1
3	3120400001	FK10×20+CL10×20	Pin	1
4	3040100045	GB/T5783-M10×30- 8.8-EP•Zn	Full-thread hexagon bolts	1
5	3040100069	GB/T5783-M12×35- 8.8-EP•Zn	Full-thread hexagon bolts	2
6	3040100021	GB/T5783-M8×16-8.8-EP•Zn	Full-thread hexagon bolts	1
7	3040100022	GB/T5783-M8×20-8.8-EP•Zn	Full-thread hexagon bolts	6
8	3060300006	GB/T70.2-M6×16-8.8-EP•Zn	Hexagon socket button head screws	4

9	3060300004	GB/T70.2-M8×20-8.8-EP•Zn	Hexagon socket button head screws	3
10	3050500004	GB/T889.1-M10-8-EP•Zn	Locknut	2
11	3050500002	GB/T889.1-M6-8-EP•Zn	Locknut	4
12	3050500003	GB/T889.1-M8-8-EP•Zn	Locknut	2
13	3080500009	GB/T93-12-EP•Zn	Spring washer	2
14	3080500007	GB/T93-8-EP•Zn	Spring washer	8
15	3080100004	GB/T95-8-EP•Zn	Plain washer	7
16	3080200008	GB/T96.2-8-EP•Zn	Large plain washer	6
17	2000006144	W01017A03000-001	Plate	1
18	2000006143	W01017A03000-002	Cover Plate	1
19	2010005737	W01017A03000-003	Pin	1
20	2000006145	W01017A03000-004	Plate	1
21	2020007247	W01017A03100-000	Bucket Welding	1
22	2020007253	W01017A03200-000	Mount	1
23	2020007248	W01017A03300-000	Controller	1
24	2010005734	W01017A05000-001	Spacer sleeve	2
25	3110200627	Y I -3×23×10×100×11-R-65Mn-EP•Zn	Pressure spring	1
26	3120500643	OEM-504左	Bolt	1
27	3190200639	DC12V-22-green	Button	1
28	3190200640	DC12V-22-yellow	Button	1
29	3190600611	ZG3-20T-4	4.3" Screen	1

DISCHARGE ASSEMBLY

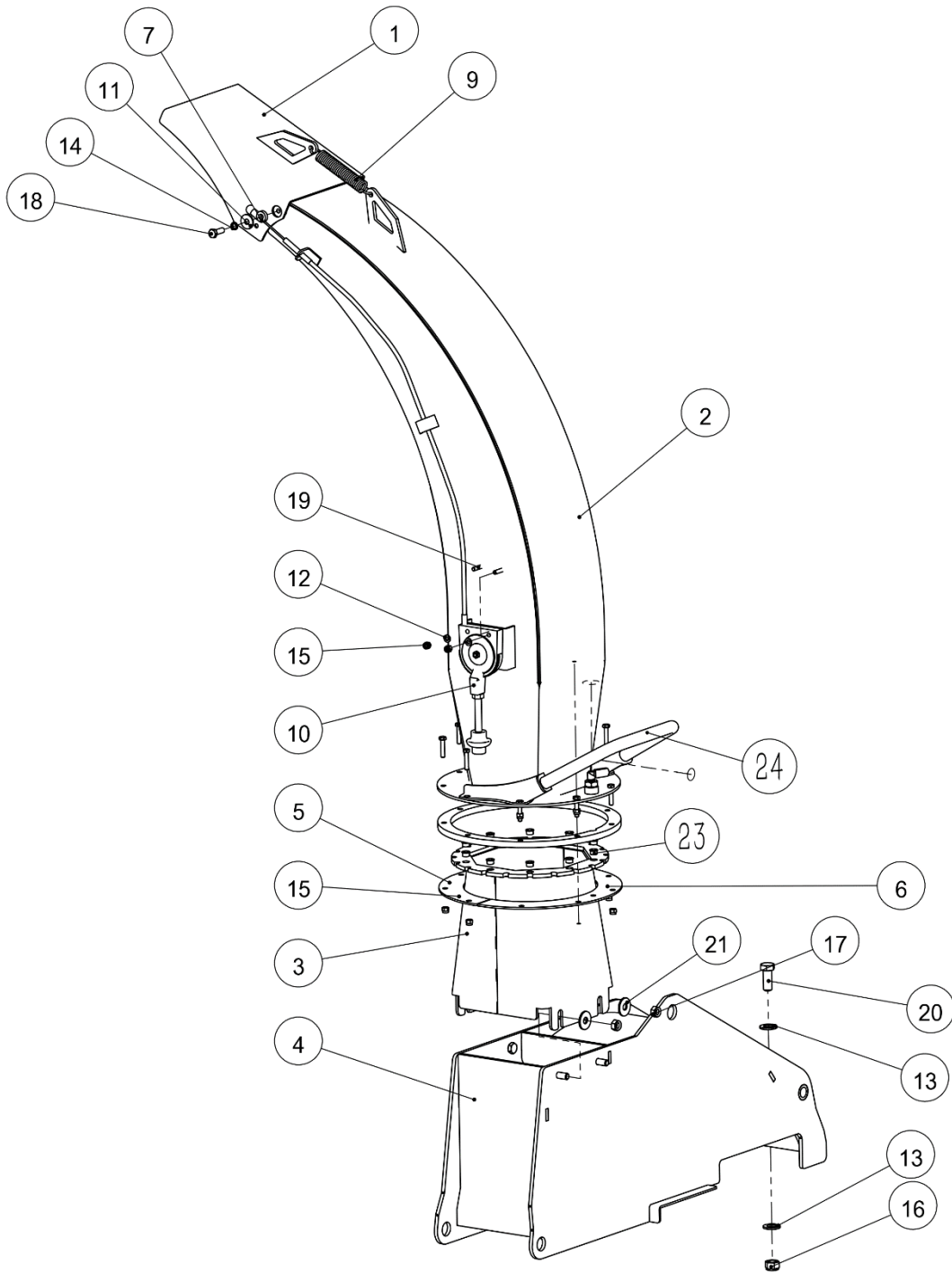

POS.	COD.	Specification	Description	Qty
1	2020007260	W01017A06500-000	Outlet baffle	1
2	2020007259	W01017A06400-000	Outlet baffle	1
3	2020007261	W01017A06200-000	Connecting seat	1
4	2020007221	W01017A06100-000	Flap	1
5	2000006150	W01017A06000-005	Plate	1
6	2000006148	W01017A06000-004	Plate	1
7	2000006149	W01017A06000-003	Ring	2
8	3210500708	W01017A06000-001	Nylon gasket	1
9	3110100609	L I -3×21×135×29-R- 65Mn-EP_Zn	Tension spring	1
10	3130400604	GJ1103A	Rope	1
11	3080200008	GB/T96.2-8-EP•Zn	Large plain washer	2
12	3080100003	GB/T95-6-EP•Zn	Plain washer	2
13	3080100008	GB/T95-14-EP•Zn	Plain washer	2
14	3080500007	GB/T93-8-EP•Zn	Spring washer	2
15	3050500002	GB/T889.1-M6-8- EP•Zn	Locknut	11
16	3050500008	GB/T889.1-M14-8- EP•Zn	Locknut	1
17	3050500004	GB/T889.1-M10-8- EP•Zn	Locknut	4
18	3040100024	GB/T5783-M8×25- 8.8-EP•Zn	Full-thread hexagon bolts	2
19	3040100009	GB/T5783-M6×30- 8.8-EP•Zn	Full-thread hexagon bolts	11
20	3040100091	GB/T5783-M14×35- 8.8-EP•Zn	Full-thread hexagon bolts	1
21	3080200009	GB/T96.2-10-EP•Zn	Large plain washer	4
22	3140100625	OEM-V69-5	swivel joint	1
23	3140400601	BCHA11	Ball Floating Support	10
24	2020007469	W01017A06600-000	Handle Weldments	1

HYDRAULIC PIPELINE

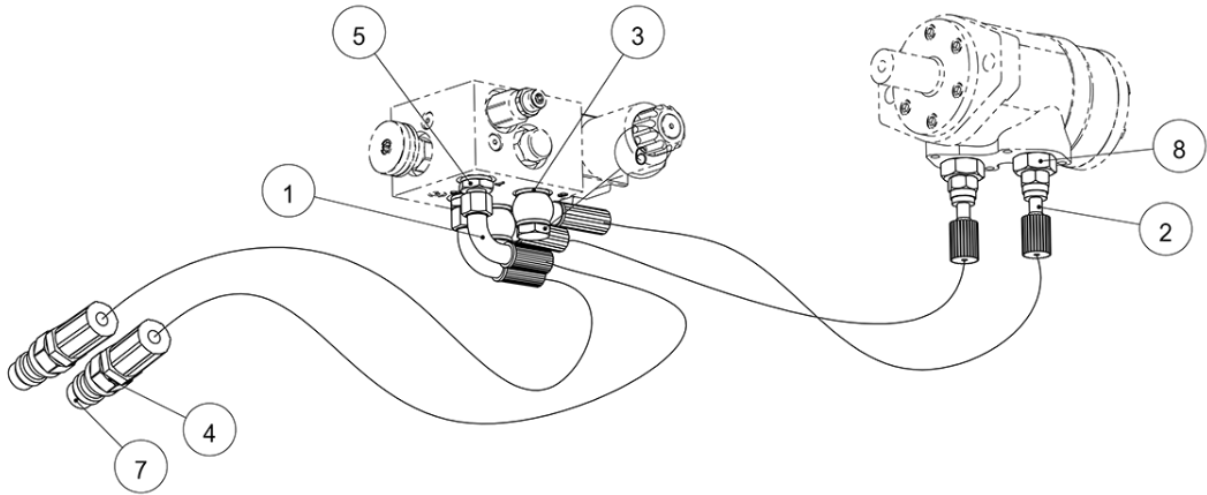

POS.	COD.	Specification	Description	Qty
1	3180201085	2SC10BL×M21592-06-16/M10510-06-08×3000+04	Hose	2
2	3180201086	2SC10BL×O20310-06-06/M22512-06-06×650+04	Hose	2
3	3170300002	BS/A-17.2×23.8×2.5- Q235	Combined sealing gaskets	4
4	3170300006	BS/A-21.5×28.6×2.5- Q235	Combined sealing gaskets	2
6	3180300004	G3/8-38.5-9-28.5	Hollow bolt	2
7	3180500001	Q00211041A-08-08	Hollow bolt	2
8	3180100104	TL-GE10UNF7/8- 14OMDCF	Transition joints	2

WARRANTY

The Manufacturer warrants to the original purchaser that this product will be free from defects in material and workmanship beginning on the date of purchase by the end user according to the following schedule when used as intended and under normal service and conditions for personal use.

Overall Unit and Driveline: 2 years Parts and Labor

Blades and Belts: Consumable part

This Warranty is limited to the replacement of any defective part by the Manufacturer and the installation by the dealer of any such replacement part, and does not cover common wear items. The Manufacturer reserves the right to inspect any equipment or parts which are claimed to have been defective in material or workmanship.

This Warranty does not apply to any part or product which in Manufacturer's judgment shall have been misused or damaged by accident or lack of normal maintenance or care, or which has been repaired or altered in a way which adversely affects its performance or reliability, or which has been used for a purpose for which the product is not designed. Misuse also specifically includes failure to properly maintain oil levels, grease points, and driveline shafts.

Claims under this Warranty should be made to the dealer which originally sold the product and all warranty adjustments must be made through an authorized Manufacturer dealer. The Manufacturer reserves the right to make changes in materials or design of the product at any time without notice.

This Warranty shall not be interpreted to render Manufacturer liable for damages of any kind, direct, consequential, or contingent to property. Furthermore, the Manufacturer shall not be liable for damages resulting from any cause beyond its reasonable control. This Warranty does not extend to loss of crops, any expense or loss for labor, supplies, rental machinery or for any other reason.

No other warranty of any kind whatsoever, express or implied, is made with respect to this sale; and all implied warranties of merchantability and fitness for a particular purpose which exceed the obligations set forth in this written warranty are hereby disclaimed and excluded from this sale.

MATENG®

Enjoy Your Farming Life